

IoT Smart Home Simulator

Complete Master Build Guide

Guides 1-10 & Full Material List



Prepared by Sonny Bever

Copyright © 2026 Sonny Bever. All rights reserved.

For classroom, booth, and smart-home simulator training use.

TABLE OF CONTENTS

IoT Smart Home Simulator

Complete Master Build Guide

Includes: Guides 1-10 & Full Material List

Material and Hardware List	3
Section 1 - Building the frame	6
Section 2 - Box cutouts	10
Section 3 - Electrical wiring	18
Section 4 - Networking	24
Section 5 - Router Configuration	30
Section 6 - Alexa show and app configuration	36
Section 7 - Build the HVAC simulator box	41
Section 8 - Smart Thermostat configuration	47
Section 9 - Routines and Demos	52
Section 10 - Router Network Hardening	56

MATERIALS and HARDWARE

QTY	ITEM	SPEC / NOTES
2	2x4 Studs, 8 ft / 96"	Each board yields one rail and one stile. Cut leg/foot stock off each end first.
1	1/2" Drywall Sheet	Cut to fit inside frame; face rests on the 1/2" ledge.
20	R4 Multi-Purpose Screws 9x2-21/2"	Frame corner assembly plus drywall-to-ledge fastening.
As needed	Sandpaper / sanding block	Smooth proud screw heads and rough drywall edges.
2	Old-work single-gang boxes	Blue plastic boxes for outlets, switches, and smart modules. Choose boxes with drywall clamp ears.
2	Round old-work light boxes or rings	Use fixture-rated boxes for any real line-voltage light. Low-voltage demo lights may use low-voltage rings if allowed by the instructor.
As needed	Face plates / device plates	Use plates during mockup to verify final visual spacing and coverage.
As needed	Cable clamps / bushings	Protect wire where it enters boxes. Use strain relief for cords and power strips.
1	Power-strip plug adapter / cord end	Training-wall feed from the protected power strip. Must be enclosed, strain-relieved, and inspected before use.
1 roll	Painter's tape	Temporary layout marks; easier to move than pencil lines.
1	Label tape or marker	Label every opening before wiring begins.
1	Power strip	Listed/approved strip with intact cord, switch, breaker, and a flat back suitable for Velcro mounting.
1	Plug adapter / cord feed	Instructor-approved feed from the power strip to the simulator wiring.
1	Single outlet / receptacle	Installed in plug box 1. Match device rating to simulator load.
2	Light sockets	Mounted in the two round light boxes. Match socket rating to lamps used.
6'	Romex / NM-B wire	Use the wire gauge and type approved for the training simulator.

As needed	Wire connectors / caps	Correct size for conductor count and wire gauge.
As needed	Cable clamps / strain relief	Required at cord feed and box entries where applicable.
As needed	Heavy-duty Velcro strips	Primary method for securing the power strip to the frame without drilling into the strip.
1	SOHO router	5 ports labeled IN, OUT1, OUT2, OUT3, OUT4.
1	Patch panel	Use at least 8 ports. Ports 1-5 = router ports; 7-8 = keystone runs.
2	Keystone jacks	Install in the single low-voltage box and label 7 and 8.
25'	CAT cable	Use consistent cable type for all runs; leave service loops for maintenance.
2	Additional patch cables	Patch panel port 4 to port 7 and port 5 to port 8 after termination/testing.
15	RJ45 ends / boots	For patch cables or any router-side RJ45 terminations.
1	Punch-down tool	For patch panel and keystone terminations.
1	Cable tester	Use with known-good patch cables to test every connection.
As needed	Velcro ties / clips / labels	Secure and label all cable routes.
1	Smart thermostat and wall/base plate	Thermostat used to control the simulator calls.
1	Project box (3x6x2 min.)	Holds colored 24V LEDs and internal wiring.
1	24V AC low-voltage supply	Instructor-approved transformer/power supply sized for simulator load.
5	Colored 24V LED indicators	24Vac/power, cool, fan, heat, and stage 2 indicators.
5'	Thermostat, wire 5-7 conductor	5-conductor preferred for R, C, W, Y, G.
As needed	Small wire nuts	Use for low-voltage splices inside the project box; size to match conductor count and gauge.
As needed	Standoffs / brackets / backing plate	Secure the project box to the wall without stressing terminals.

As needed	Cable glands / grommets	Protect thermostat and power-supply wires where they enter the box.
As needed	Labels / wire markers	Label both ends of each conductor.
1	Multimeter	Verify low-voltage output and continuity before final test.
1	In-line fuse 1amp	1 amp Inline fuse for power supply wire.

Smart Home Simulator — Build Guide 01

Frame, Drywall Ledge, Cut List, and Panel Assembly

TYPE	FRAME METHOD	SURFACE	USE
Tabletop Simulator Panel	2x4 Square-Notched + Mitered	1/2" Drywall	IoT / Smart Home Training

SAFETY:

Use eye and ear protection for saw operations. Wear a dust mask when cutting drywall. Support long boards and sheet goods during cuts. Keep hands clear of blades and clamp work before drilling or fastening.

GOAL OF THIS PHASE

Build a rigid tabletop wall panel with a 2x4 frame and a recessed 1/2" drywall face. The inside edge of every frame member receives a square ledge so the drywall rests flat and screws into the frame cleanly.

- Cut the 1/2" x 1/2" square notch on all 2x4 pieces before miter cuts.
- Keep the ledge facing inward on all rails and stiles.
- Measure diagonals before final screws so the frame stays square.
- Do not over-drive drywall screws; set them just below the paper surface.

MATERIALS, HARDWARE & TOOLS

QTY	ITEM	SPEC / NOTES
2	2x4 Studs, 8 ft / 96"	Each board yields one rail and one stile. Cut leg/foot stock off each end first.
1	1/2" Drywall Sheet	Cut to fit inside frame; face rests on the 1/2" ledge.
20	R4 Multi-Purpose Screws 9x2-21/2"	Frame corner assembly plus drywall-to-ledge fastening.
As needed	Sandpaper / sanding block	Smooth proud screw heads and rough drywall edges.

RECOMMENDED TOOLS
Table saw for two rip passes

BUILD RULES
Cut leg stock before ripping the ledge

Miter saw for 45 degree cuts
 Drill / driver and countersink bit
 Speed square and tape measure
 Drywall knife and T-square

Rip the notch before mitering final lengths
 Pre-drill near board ends to prevent splits
 Check both diagonals before final screws
 Screw drywall into the ledge every 12"
 Panel must sit flat before cutouts begin

2X4 PREP — SQUARE NOTCH & FULL-LENGTH RIP

NOTE: The inside corner of the 2x4 gets a SQUARE notch: 1/2" wide x 1/2" deep, running the full length of the board. This leaves a flat 1/2" ledge. The drywall face rests on this ledge and is screwed into it.

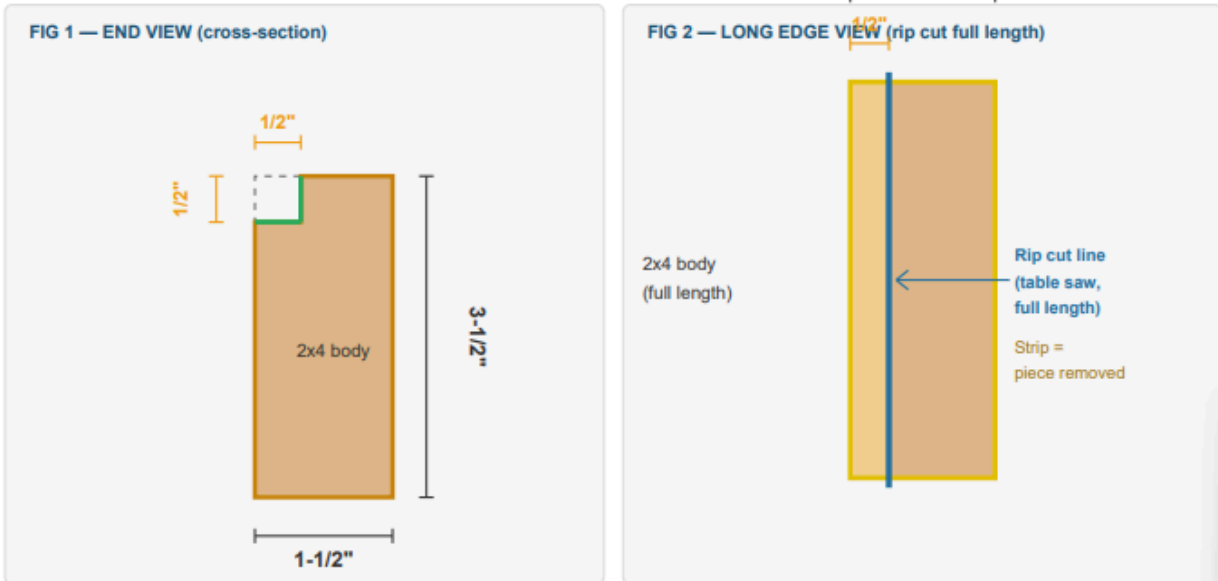

Fig 1 (left) — End view: 2x4 cross-section with 1/2" x 1/2" square notch, green = ledge | Fig 2 (right) — Long edge: rip cut runs full board length



Fig 3 — Corner joint: green dashed lines = 1/2" x 1/2" interior ledge on stile and rail — drywall screws to this ledge

CUT LIST

SIZE:	Dimensions assume a 48" x 24" panel. Adjust to your wall size. Always confirm actual ledge-to-ledge drywall size before cutting the drywall panel.
--------------	--

PIECE	QTY	RAW LENGTH	MITER	NOTES
Top Rail	1	43"	45 deg both ends	Outside dimension
Bottom Rail	1	43"	45 deg both ends	Outside dimension
Left Stile	1	26"	45 deg both ends	Outside dimension
Right Stile	1	26"	45 deg both ends	Outside dimension
Drywall Panel	1	41" x 24"	Square cuts	Rests on 1/2" inside ledge all around
Bottom Foot	2	16"	Square cuts	Outside Dimension

STEP-BY-STEP BUILD INSTRUCTION

- 1** Cut the 16" leg/foot stock off each 2x4 first
Before any ripping, cut the leg or foot piece from each 8 ft board. Plan lengths so each board still yields one rail and one stile.
- 2** Cut the 1/2" x 1/2" square notch
Make two rip passes on the table saw: one along the face and one along the edge. The ledge must run the full board length.
- 3** Miter cut all four frame pieces
Set the miter saw to 45 degrees. Rails target the outside width; stiles target the outside height. Keep the ledge facing inward.
- 4** Dry-fit and square the frame
Lay all four pieces flat. Measure both diagonals. Equal diagonals mean the frame is square.

5**Assemble frame with 2.5" screws**

Pre-drill at each miter corner. Use two - three screws per corner and verify square before fully seating.

6**Cut drywall to size.**

Measure ledge-to-ledge on all sides. Score the front paper, snap the drywall, and cut the backing paper. Test-fit before final install.

7**Set drywall on the ledge and screw.**

Rest the drywall face on the 1/2" ledge all around. Drive screws through the drywall face into the ledge about every 12".

8**Final check before cutouts.**

The panel should be rigid, corners tight, screw heads just below the surface, and the frame sitting flat.

FINAL FRAME CHECKLIST

CHECK	PASS CRITERIA	STATUS
Frame square	Both diagonal measurements match.	<input type="checkbox"/> Pass
Ledge direction	All four ledges face inward toward the drywall.	<input type="checkbox"/> Pass
Corners tight	45 degree miters close without large gaps.	<input type="checkbox"/> Pass
Drywall seated	Drywall rests flat on the ledge around the full perimeter.	<input type="checkbox"/> Pass
Screws set	Screw heads sit just below the paper and do not break through.	<input type="checkbox"/> Pass
Panel stable	Frame sits flat and does not wobble during layout work.	<input type="checkbox"/> Pass

NEXT PHASE — BOX LAYOUT & CUTOUTS

READY FOR GUIDE 02

Single-gang electrical boxes
 Round light boxes
 Outlet and device plates
 Painter's tape layout
 Cutout marking and drilling

DO NOT SKIP

Confirm panel is square before cutouts
 Keep boxes clear of frame members
 Check front layout and rear clearance
 Label openings before wiring
 Vacuum drywall dust after cutting

Smart Home Simulator — Build Guide 02

Mocking Up, Cutting Out, Installing, and Rough-Wiring Plug & Light Boxes

TYPE	PHASE	SURFACE	USE
Tabletop Simulator Panel	Box Layout + Cutouts	1/2" Drywall in 2x4 frame	IoT / Smart Home Training

SAFETY:

This build guide covers mechanical layout and mounting. Do not connect exposed 120V wiring on a training wall. Keep the simulator unplugged while cutting, drilling, or installing boxes.

GOAL OF THIS PHASE

In this phase you will mock up the smart-home devices on the drywall face, mark the openings, cut clean holes, and install the plug and light boxes so the simulator is ready for device wiring and face plates.

- Use the actual box, ring, or device plate as the layout template whenever possible.
- Confirm the look from the front and the working clearance from the back before cutting.
- Cut openings slightly tight first; trim only after a test fit.
- Keep boxes clear of the frame ledge, legs, screw heads, and any planned router or patch-panel hardware.

MATERIALS, HARDWARE & TOOLS

QTY	ITEM	SPEC / NOTES
2	Old-work single-gang boxes	Blue plastic boxes for outlets, switches, and smart modules. Choose boxes with drywall clamp ears.
2	Round old-work light boxes or rings	Use fixture-rated boxes for any real line-voltage light. Low-voltage demo lights may use low-voltage rings if allowed by the instructor.
As needed	Face plates / device plates	Use plates during mockup to verify final visual spacing and coverage.
As needed	Cable clamps / bushings	Protect wire where it enters boxes. Use strain relief for cords and power strips.
As needed	Romex / NM-B electrical wire	Use the wire gauge and type approved by the instructor for the training simulator load.
1	Power-strip plug adapter / cord end	Training-wall feed from the protected power strip. Must be enclosed, strain-relieved, and inspected before use.

1 roll	Painter's tape	Temporary layout marks; easier to move than pencil lines.
1	Label tape or marker	Label every opening before wiring begins.

RECOMMENDED TOOLS Tape measure, pencil, level, speed square Oscillating multi-tool with drywall blade Drywall jab saw or utility knife Hole saw for round light openings Drill and small pilot bit Vacuum and sanding block	LAYOUT RULES Minimum 2" clearance between cutouts Stay at least 2" away from frame members Keep device plates level and aligned Leave rear access for wire routing Never cut through hidden wiring Dry-fit every box before final screws
--	---

MOCK UP THE FRONT LAYOUT

The best layout is the one that looks correct from the front and still leaves enough room behind the wall to route cables. Start with tape, not holes.

Recommended mockup layout before cutting

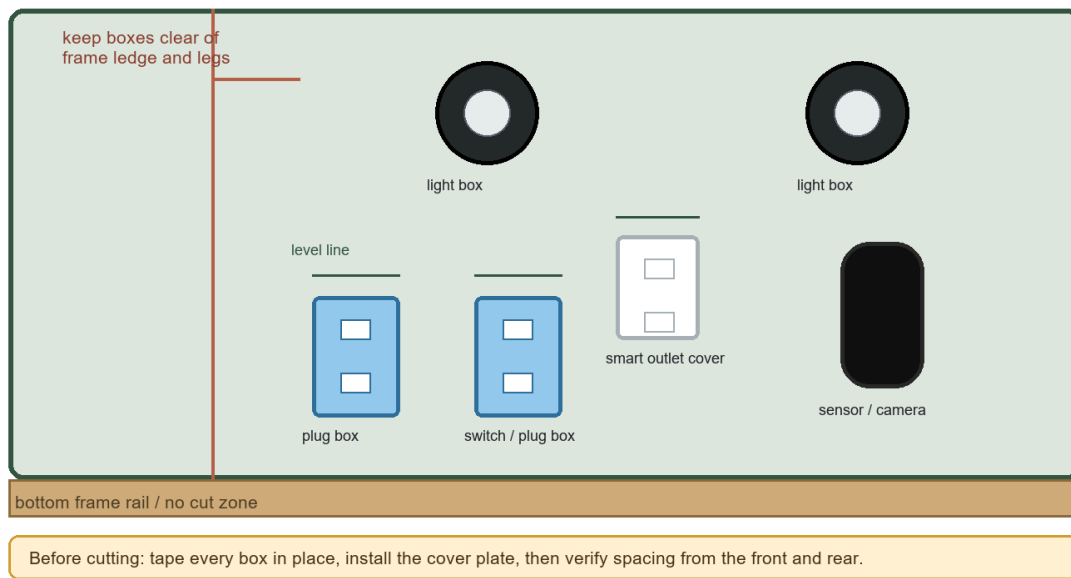

Fig 1 — Example front layout: tape boxes in place first, then check level, spacing, and back-side clearance before cutting.

- 1** **Mark a level reference line**
Draw a light pencil or tape line across the working area. Use it to align outlets, switches, and smart outlet plates.

2

Tape boxes and cover plates to the wall

Temporarily tape the box and its face plate in place. The face plate shows what students will actually see after installation.

3

Check spacing from the front

Leave enough room for labels, hands, plugs, adapters, and power cords. Avoid crowding devices near the frame.

4

Check clearance from the back

Make sure clamp ears, cable exits, power strips, and router hardware will not collide behind the panel.

5

Label each future opening

Write OUTLET, SWITCH, LIGHT 1, LIGHT 2, SENSOR, or the planned device name on tape above the opening.

TRACE AND CUT THE OPENINGS

Cutout sequence

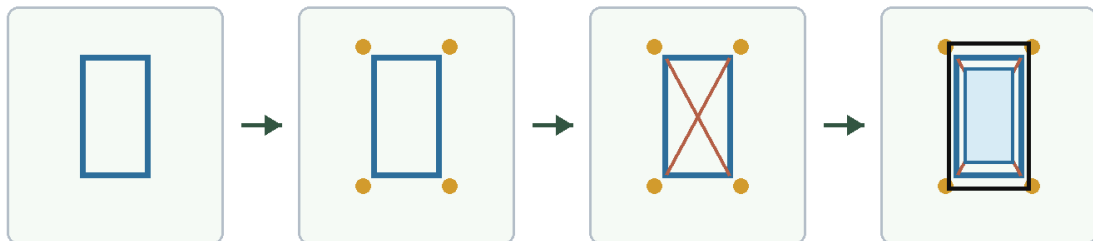

1. Trace box

Use the actual box or template. Mark level and center lines.

2. Pilot holes

Drill inside the waste area. Stay inside the pencil line.

3. Cut opening

Use oscillating tool or jab saw. Cut slightly tight first.

4. Test fit

Box ears sit flush. Cover plate hides the cut edge.

Fig 2 — Cut slightly inside the line first. A tight opening can be trimmed; an oversized opening is hard to hide.

TIP:

For rectangular plug boxes, trace the box body, not the cover plate. For round light boxes, use the manufacturer template or trace the box body. Keep the box ears or mounting flange on the face side of the drywall.

1

Trace the box outline

Hold the box level and trace around the cutout body. Mark which side is top. For old-work boxes, keep the clamp-ear area outside the opening.

2

Drill starter holes in the waste area

Drill inside the traced shape, near corners for rectangular boxes. The holes give the saw a clean place to start.

3

Score the paper face

Lightly score the cut line with a utility knife. This reduces paper tear-out and gives the saw a clear path.

4

Cut just inside the line. Support the panel from behind if it flexes. Vacuum dust as you go so the line stays visible.

5

Test fit and trim

Insert the box without forcing it. Trim high spots a little at a time until the box seats square and flush.

INSTALL PLUG BOXES

1

Prepare the box

Open only the knockouts you need. Install bushings or clamps before the box goes into the wall.

2

Route cable into the box

Feed cable through the knockout with enough slack for device installation. Keep slack neat behind the panel.

3

Seat the box flush

Push the box into the opening until the front ears sit flat against the drywall face.

4

Tighten old-work clamps

Tighten clamp screws until the box is secure. Stop when snug; over-tightening can crush drywall.

5

Check the plate fit

Temporarily install the outlet, blank, or smart-device plate. It should sit level and cover the cut edge cleanly.

INSTALL LIGHT BOXES

1 Confirm the box rating
Use fixture-rated boxes for real lights. For LED/demo-only modules, follow the instructor-approved low-voltage mounting method.

2 Cut the round opening
Use a hole saw when possible. If using an oscillating tool, trace carefully and cut slowly so the circle stays clean.

3 Feed cable and add strain relief
Protect wire where it passes into the box. Keep low-voltage and line-voltage circuits separated.

4 Seat and fasten the box
Old-work round boxes clamp to the drywall. Surface brackets should be screwed into backing or rated anchors.

5 Install a temporary cover
Install a blank cover or fixture ring during the build so the opening is protected before wiring begins.

RUN ROMEX FROM THE POWER STRIP FEED

After the holes are cut and the boxes are mounted, rough-in the electrical path before installing devices. This simulator uses one single outlet box as the powered plug box, two round light boxes, and one separate single-gang box reserved for keystone/CAT cables in a later step.

Romex rough-in route after boxes are mounted

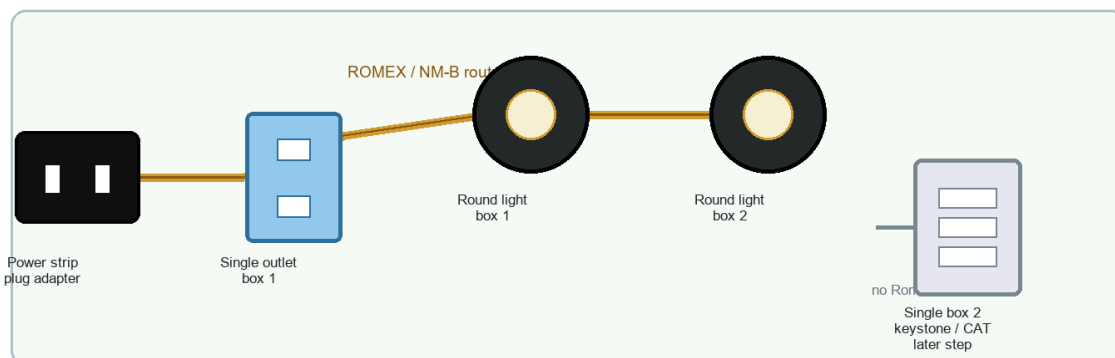

Power stays OFF during wiring. Final energizing and line-voltage approval must be done by the instructor or a qualified electrician.

Fig 3 — Rough-in route: power strip plug adapter to outlet box 1, then light box 1, then light box 2. The second single-gang box is for low-voltage keystone/CAT cable only.

POWER OFF:	Keep the power strip unplugged while routing or terminating wire. Do not energize the simulator until all boxes are covered, the cord feed is strain-relieved, grounds are bonded where required, and the instructor or qualified electrician has inspected the wiring.
-------------------	---

LEG	FROM	TO	PURPOSE
1	Power strip plug adapter / cord feed	Single outlet box 1	Brings protected simulator power into the first plug box.
2	Single outlet box 1	Round light box 1	Continues power path from the plug box to the first light point.
3	Round light box 1	Round light box 2	Continues power path to the second light point.
Hold	Single outlet box 2	Keystone / CAT cable later	Do not run Romex into this box unless the design changes. Reserve it for low-voltage data cables.

1 **Prepare the power-strip feed**
Use the approved plug adapter or cord end from the power strip as the simulator feed. Add strain relief so a tug on the cord cannot pull wire loose inside the box or panel.

2 **Run Romex to single outlet box 1**
Route the Romex from the power-strip feed into the first single outlet box. Leave enough service loop to terminate the device without tension, then secure the cable so it cannot sag into moving or sharp areas.

3 **Terminate outlet box 1**
Inside the first plug box, connect the feed conductors to the outlet/device following the device markings and instructor-approved wiring method. Keep insulation intact up to the terminal area and fold conductors neatly into the box.

4 **Run Romex from outlet box 1 to round light box 1**
Route the next Romex leg from the first plug box into the first round light box. Protect the cable at every box entry with the proper clamp or bushing.

5

Run Romex from round light box 1 to round light box 2
Continue the route from the first round light box to the second round light box. Leave slack for fixture/device connections and keep the cable path neat on the back side of the wall.

6

Cap, cover, and label unfinished conductors
If lights or devices are not installed immediately, cap conductors individually, install temporary blank covers, and label each box before any power is applied.

7

Leave single outlet box 2 for data
Do not connect this box to the power feed. Mark it KEYSTONE / CAT so it is ready for the later low-voltage networking step.

PHOTO REFERENCES

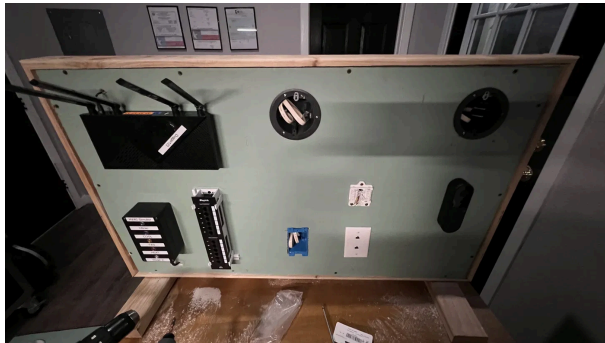

Front reference — boxes, plates, round openings, and equipment layout after mockup.



Rear reference — old-work boxes, cable paths, and back-side access before final wiring.

FINAL FIT CHECKLIST

CHECK	PASS CRITERIA	STATUS
-------	---------------	--------

Box flush	Box ears touch drywall face; no rocking or proud corners.	<input type="checkbox"/> Pass
Plate coverage	Cover plate hides cut edge on all sides.	<input type="checkbox"/> Pass
Level / plumb	Outlets and switches align with the reference line.	<input type="checkbox"/> Pass
Rear clearance	Clamp ears, cable exits, and cords do not hit frame or other devices.	<input type="checkbox"/> Pass
Cable protection	Bushings, clamps, and strain relief are installed where needed.	<input type="checkbox"/> Pass
Romex path	Feed runs to plug box 1, then light box 1, then light box 2.	<input type="checkbox"/> Pass
Data box reserved	Second single-gang box is marked keystone/CAT and has no power conductors.	<input type="checkbox"/> Pass
Dust cleanup	Cutout dust vacuumed from front, rear, and device boxes.	<input type="checkbox"/> Pass
Labels	Each opening/device is labeled before wiring starts.	<input type="checkbox"/> Pass

NEXT PHASE — DEVICES, KEYSTONE & LABELS

<p>READY FOR DEVICE WORK</p> <ul style="list-style-type: none"> Smart outlet or plug module Switch or scene button Light module or LED fixture Sensor, camera, or doorbell mount Router / hub / patch panel mounting Keystone and CAT cable install 	<p>DO NOT SKIP</p> <ul style="list-style-type: none"> Verify power is disconnected before device work Separate low-voltage and line-voltage paths Use strain relief on cords and cable entries Label each circuit and simulator function Test with instructor-approved power only
--	---

Smart Home Simulator — Build Guide 03

Electrical Plug, Light Sockets, Plug Adapter, and Power Strip Mounting

TYPE	PHASE	POWER PATH	USE
Tabletop Simulator Panel	Electrical Device Wiring	Power strip feed to outlet and lights	IoT / Smart Home Training

SAFETY:

This guide is for an instructor-approved training simulator, not building wiring. Keep the power strip unplugged while wiring. Final energizing must wait until every connection is enclosed, the cord feed is strain-relieved, the power strip is mounted without damage, and an instructor or qualified electrician has inspected the work.

GOAL OF THIS PHASE

Wire the simulator power path from the secured power strip and plug adapter to the first single outlet box, then continue to two round light socket boxes. The second single-gang box from Guide 02 remains reserved for keystone/CAT cable work and is not part of this electrical circuit.

- Use only the instructor-approved wire size, device ratings, plug adapter, light sockets, and power strip.
- Do not energize open boxes, exposed conductors, loose sockets, or an unsecured power strip.
- Keep line-voltage wiring separated from later CAT/keystone low-voltage wiring.
- Do not drill through the power strip case or fasten through the cord.

MATERIALS, HARDWARE & TOOLS

QTY	ITEM	SPEC / NOTES
1	Power strip	Listed/approved strip with intact cord, switch, breaker, and a flat back suitable for Velcro mounting.
1	Plug adapter / cord feed	Instructor-approved feed from the power strip to the simulator wiring.
1	Single outlet / receptacle	Installed in plug box 1. Match device rating to simulator load.
2	Light sockets	Mounted in the two round light boxes. Match socket rating to lamps used.

6'	Romex / NM-B wire	Use the wire gauge and type approved for the training simulator.
As needed	Wire connectors / caps	Correct size for conductor count and wire gauge.
As needed	Cable clamps / strain relief	Required at cord feed and box entries where applicable.
As needed	Heavy-duty Velcro strips	Primary method for securing the power strip to the frame without drilling into the strip.

POWER PATH OVERVIEW

Electrical wiring sequence

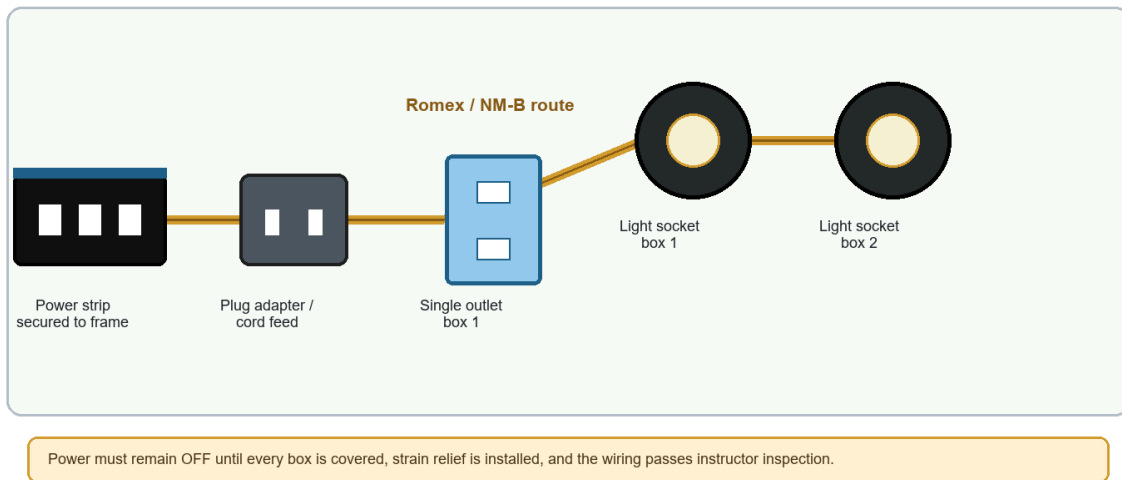

Fig 1 — Wiring path: secured power strip, plug adapter/feed, outlet box 1, light socket box 1, then light socket box 2.

LEG	FROM	TO	PURPOSE
1	Power strip plug adapter / cord feed	Single outlet box 1	Brings protected simulator power into the device circuit.
2	Single outlet box 1	Round light socket box 1	Continues hot, neutral, and ground to first light point.
3	Round light socket box 1	Round light socket box 2	Continues hot, neutral, and ground to second light point.
Hold	Single outlet box 2	Keystone / CAT later	No electrical power conductors in this box.

TERMINAL COLOR GUIDE

Terminal color guide

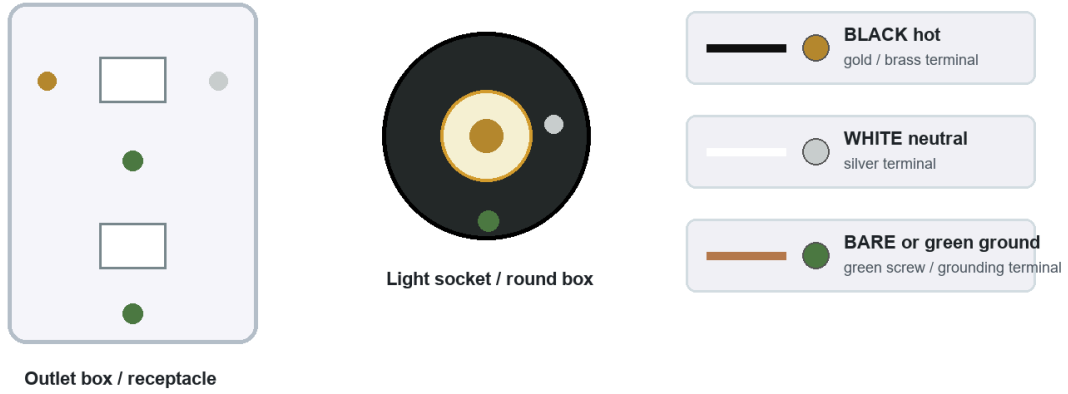
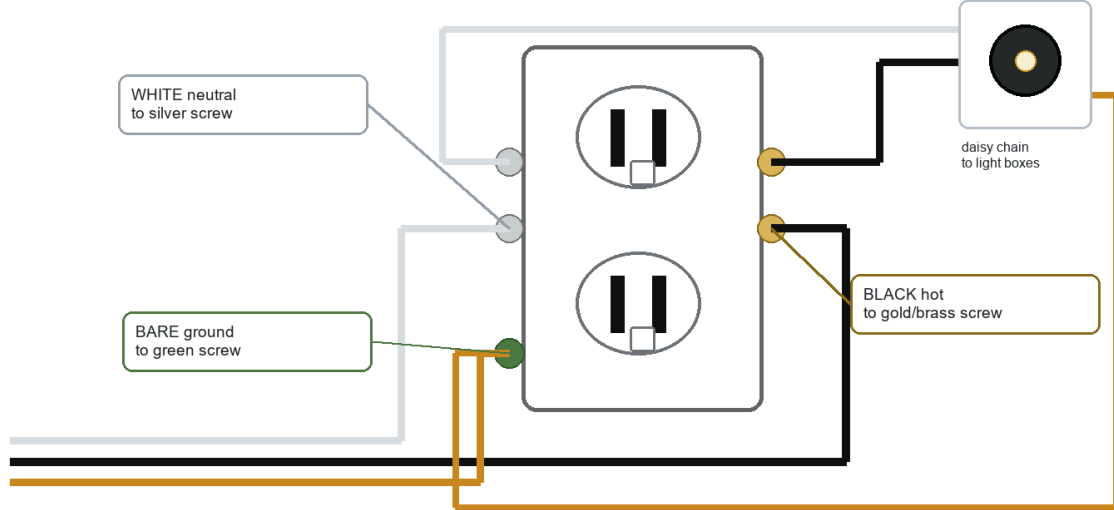

Fig 2 — Common terminal colors: black hot to gold/brass, white neutral to silver, bare/green ground to green grounding screw when used.

WIRE	FUNCTION	TERMINAL	CHECK
Black	Hot / line	Gold or brass screw	No copper exposed outside terminal area.
White	Neutral	Silver screw	Connected only to neutral terminal group.
Bare copper / green	Equipment ground	Green screw or grounding terminal	Bond to metal boxes or grounding points where required.

Single outlet box 1: receptacle terminal detail



Keep the box open only while power is disconnected. Install the device and cover plate before testing.

Fig 3 — Outlet detail matching the reference image: white to silver side, black to gold/brass side, and bare ground to green grounding screw.

WIRE THE PLUG ADAPTER AND FIRST OUTLET

- 1** Confirm power is disconnected
Unplug the power strip from the wall and switch it OFF. Use a tester only after instructor approval. Never work on an energized circuit.
- 2** Secure the feed into an enclosure
Route the plug adapter or cord feed into the approved box or enclosure with strain relief. A pull on the cord must not transfer force to the terminals.
- 3** Prepare outlet box 1
Bring the feed conductors and outgoing Romex leg into the first outlet box. Leave a service loop so the receptacle can be pulled forward for inspection.
- 4** Connect the receptacle by terminal color
Connect black hot to the gold/brass terminal, white neutral to the silver terminal, and bare/green ground to the green grounding screw if the device uses one.

5

Continue the circuit to light box 1

Use the outgoing Romex leg from outlet box 1 to carry hot, neutral, and ground toward the first round light box. Cap or pigtail conductors using the instructor-approved method.

WIRE THE TWO LIGHT SOCKETS

1

Prepare light box 1

Bring the Romex from outlet box 1 into round light box 1. Bring the outgoing Romex to round light box 2 into the same box.

2

Connect light socket 1

Connect black hot to the socket hot terminal, white neutral to the socket silver/neutral terminal, and bare/green ground to the green grounding point if provided.

3

Continue to light box 2

Join or pigtail the continuing hot, neutral, and ground conductors so the second light socket receives the same protected feed path.

4

Connect light socket 2

At round light box 2, connect black to hot/gold, white to neutral/silver, and bare/green to green grounding point if provided.

5

Install covers or fixtures

No round box should remain open before power is applied. Install the socket, lamp holder, blank cover, or approved fixture ring.

SECURE THE POWER STRIP TO THE FRAME

1

Choose the mounting location

Place the power strip where the switch and breaker are visible, the cord has a smooth path, and plugs will not stick out into a walking or work area.

2

Attach heavy-duty Velcro

Apply heavy-duty Velcro to the back of the power strip and the clean frame surface. Press firmly so the strip is held flat against the frame.

3**Protect the cord**

Do not staple, pinch, sharply bend, or screw through the cord. Leave enough slack so the cord is not under tension.

4**Label the strip**

Mark it **SIMULATOR POWER** and add a note that it must be unplugged before service work.

5**Final tug and clearance check**

Gently tug the Velcro-mounted strip and cord. Nothing should move, chafe, or pull against the plug adapter/feed connection.

PRE-POWER INSPECTION CHECKLIST

CHECK	PASS CRITERIA	STATUS
Power off	Power strip is unplugged before inspection begins.	<input type="checkbox"/> Pass
Terminal colors	Black to gold/brass, white to silver, bare/green to green where used.	<input type="checkbox"/> Pass
Strain relief	Cord feed and cable entries cannot pull on terminals.	<input type="checkbox"/> Pass
Covered boxes	Outlet box and both round light boxes are covered/enclosed.	<input type="checkbox"/> Pass
No exposed copper	Only the proper conductor length is stripped at terminals/connectors.	<input type="checkbox"/> Pass
Power strip mount	Strip is secured to the frame with Velcro and the cord is not pinched or damaged.	<input type="checkbox"/> Pass
Data box separate	Keystone/CAT box has no power conductors.	<input type="checkbox"/> Pass
Instructor approval	Instructor or qualified electrician approves before energizing.	<input type="checkbox"/> Pass

NEXT PHASE — KEYSTONE, CAT CABLE & DEVICE LABELS

READY FOR LOW-VOLTAGE WORK

Keystone jack install
 CAT cable routing
 Patch-panel or router labeling
 Device labels
 Network test plan

DO NOT SKIP

Keep CAT/data cables separated from power wiring
 Label every cable end
 Use low-voltage rings/plates only for data
 Document the final port map
 Test power and network separately

Smart Home Simulator – Build Guide 04

Router Mounting, Patch Panel, CAT Cable Routing, RJ45 Ends, and Punch-Downs

TYPE	PHASE	NETWORK MAP	USE
Tabletop Simulator Panel	Low-Voltage Network Wiring	Router -> patch panel -> keystones	IoT / Smart Home Training

NOTE: Keep CAT/network wiring separated from the electrical wiring completed in Guide 03. Do not route CAT cable through electrical boxes. Install covers and secure wiring before router configuration begins.

GOAL OF THIS PHASE

Mount the SOHO router and patch panel, route CAT cable to the router ports and keystone jack box, terminate RJ45 ends and punch-downs as needed, make two additional patch cables, and test every CAT connection before moving to router configuration.

- Router has 5 labeled ports: IN, OUT1, OUT2, OUT3, OUT4.
- Router ports route to patch panel ports 1-5 labeled SOHO router ports.
- Patch panel ports 7 and 8 route to the two keystone jacks in the single box.
- Make two additional patch cables: patch panel port 4 to port 7 and patch panel port 5 to port 8.

MATERIALS, HARDWARE & TOOLS

QTY	ITEM	SPEC / NOTES
1	SOHO router	5 ports labeled IN, OUT1, OUT2, OUT3, OUT4.
1	Patch panel	Use at least 8 ports. Ports 1-5 = router ports; 7-8 = keystone runs.
2	Keystone jacks	Install in the single low-voltage box and label 7 and 8.
25'	CAT cable	Use consistent cable type for all runs; leave service loops for maintenance.
2	Additional patch cables	Patch panel port 4 to port 7 and port 5 to port 8 after termination/testing.
15	RJ45 ends / boots	For patch cables or any router-side RJ45 terminations.

1	Punch-down tool	For patch panel and keystone terminations.
1	Cable tester	Use with known-good patch cables to test every connection.
As needed	Velcro ties / clips / labels	Secure and label all cable routes.

NETWORK ROUTING MAP

Guide 04 network routing map

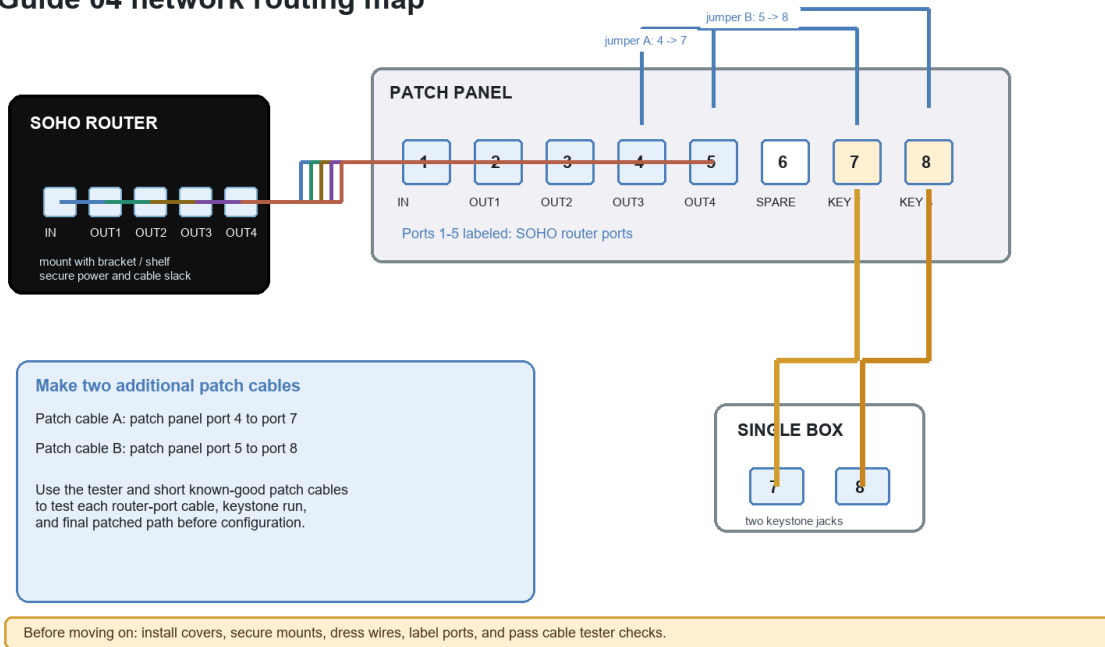

Fig 1 — Router ports route to patch panel ports 1-5; panel ports 7 and 8 route to the keystone box; two jumper patch cables connect patch panel 4 -> 7 and 5 -> 8.

PATCH PANEL PORT	LABEL	ROUTES TO	NOTES
1	SOHO IN	Router IN	Router incoming/WAN-side training port.
2	SOHO OUT1	Router OUT1	Also used for patch cable to port 7.
3	SOHO OUT2	Router OUT2	Also used for patch cable to port 8.
4	SOHO OUT3	Router OUT3	Also used for jumper patch cable to port 7.
5	SOHO OUT4	Router OUT4	Also used for jumper patch cable to port 8.
6	SPARE	Reserve	Leave blank or label spare.

7	KEYSTONE 7	Keystone jack 7	Patch from panel port 4 during final setup.
8	KEYSTONE 8	Keystone jack 8	Patch from panel port 5 during final setup.

MOUNT ROUTER AND PATCH PANEL

1 **Choose router location**
Mount the router where antennas, power cord, and patch cables have clearance. Keep the reset button and labels visible.

2 **Secure router mount**
Use the router bracket, shelf, Velcro, or approved hardware. The router should not shift when the panel is moved.

3 **Mount patch panel**
Place the panel near the router with enough room for bend radius and patch cables. Label ports before terminating.

4 **Install keystone plate**
Install two keystone jacks in the single low-voltage box. Label the jacks 7 and 8 to match the patch panel.

5 **Plan cable paths**
Route CAT cable along frame edges where possible. Keep cable away from power wiring and sharp edges.

TERMINATE RJ45 ENDS AND PUNCH-DOWNS

RJ45 ends and punch-down color order

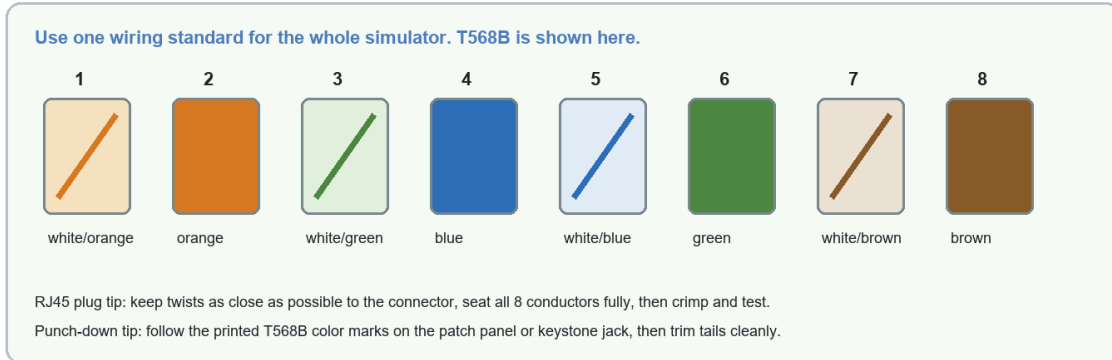

Fig 2 — T568B color order for RJ45 ends and matching punch-downs. Use the same standard on every termination.

1 Pick one standard
Use T568B for the whole simulator unless your instructor specifies T568A. Do not mix standards on the same run.

2 Terminate router-side cables
Install RJ45 ends where needed for the router ports. Keep twists close to the connector and crimp fully.

3 Punch down patch panel ports 1-5
Route the five router port cables to panel ports 1-5. Punch each cable to the printed T568B marks and label SOHO router ports.

4 Punch down keystone runs
Route patch panel 7 to keystone jack 7 and patch panel 8 to keystone jack 8. Punch both ends using the same color standard.

5 Make two additional patch cables
Build and label two patch cables: patch panel port 4 -> port 7 and patch panel port 5 -> port 8. Test each cable before using it in the simulator.

TEST CAT CONNECTIONS

TEST	FROM	TO	PASS CRITERIA
Router port run 1	Router IN cable	Patch panel 1	Pins 1-8 pass in order.
Router port run 2	Router OUT1 cable	Patch panel 2	Pins 1-8 pass in order.
Router port run 3	Router OUT2 cable	Patch panel 3	Pins 1-8 pass in order.
Router port run 4	Router OUT3 cable	Patch panel 4	Pins 1-8 pass in order.
Router port run 5	Router OUT4 cable	Patch panel 5	Pins 1-8 pass in order.
Keystone run 7	Patch panel 7	Keystone jack 7	Pins 1-8 pass in order.
Keystone run 8	Patch panel 8	Keystone jack 8	Pins 1-8 pass in order.
Patch cable A	Patch panel 4	Patch panel 7	Known-good link or tester pass.
Patch cable B	Patch panel 5	Patch panel 8	Known-good link or tester pass.

SECURE, COVER, AND DRESS CABLES

1 **Install all covers and mounts**
Install the keystone wall plate, patch panel cover or strain bar if used, router mount, and any cable-entry covers.

2 **Dress cable bundles**
Use Velcro ties or clips. Do not crush cables with zip ties. Maintain smooth bends and avoid tight kinks.

3 **Label both ends**
Label router ports, patch panel ports, keystone jacks, and patch cables so the map can be followed without guessing.

4 **Remove dust and loose scraps**
Clean up cable jacket scraps, cut wire ends, and drywall dust before powering equipment.

5

Final move check

Gently move or tilt the simulator panel. Router, patch panel, covers, and wiring should stay secure.

FINAL NETWORK CHECKLIST

CHECK	PASS CRITERIA	STATUS
Router mounted	Router is secure and ports are accessible.	<input type="checkbox"/> Pass
Patch panel mounted	Patch panel is secure and ports are labeled 1-8.	<input type="checkbox"/> Pass
Ports 1-5 mapped	IN, OUT1, OUT2, OUT3, OUT4 route to patch panel 1-5.	<input type="checkbox"/> Pass
Ports 7-8 mapped	Patch panel 7 and 8 route to keystone jacks 7 and 8.	<input type="checkbox"/> Pass
Patch cables made	Panel 4 -> 7 and panel 5 -> 8 patch cables are built and labeled.	<input type="checkbox"/> Pass
Tester passed	All CAT runs and patch cables pass with tester.	<input type="checkbox"/> Pass
Covers installed	Keystone plate, router mount, patch panel, and cable covers are installed.	<input type="checkbox"/> Pass
Wires secured	All CAT cables are secured and separated from electrical wiring.	<input type="checkbox"/> Pass

NEXT PHASE — CONFIGURE THE ROUTER**READY FOR CONFIGURATION**

Power router
 Connect admin device
 Set router login
 Configure Wi-Fi / LAN
 Document port map

DO NOT SKIP

Confirm all covers are installed
 Confirm mounts are secure
 Confirm all CAT tests passed
 Confirm patch cables are labeled
 Keep power and data separated

Smart Home Simulator — Build Guide 05

Configure the Router for the IoT Smart Home Simulator

TYPE	PHASE	EXAMPLE ROUTER	USE
Tabletop Simulator Panel	Router Configuration	TP-Link Archer AX55	IoT / Smart Home Training

FIRST: After a full reset, update firmware before configuring SSIDs. Use the correct TP-Link regional support page, match the hardware version printed on the router label, use a wired connection when possible, and do not power off during the firmware upgrade.

GOAL OF THIS PHASE

Configure the simulator router after the physical router, patch panel, keystone jacks, and CAT cable tests are complete. This guide uses the TP-Link Archer AX55 as the example and creates only the wireless networks needed for the simulator: Smart Home Admin and IoT Devices. Guest Wi-Fi stays disabled for now.

- Start from a full factory reset so every class begins from a known state.
- Update firmware before SSID configuration or smart-device enrollment.
- Use a wired admin laptop for setup whenever possible.
- Record the firmware version, admin password storage location, SSIDs, and Wi-Fi passwords.

CONFIGURATION FLOW

Router configuration flow: TP-Link Archer AX55 example

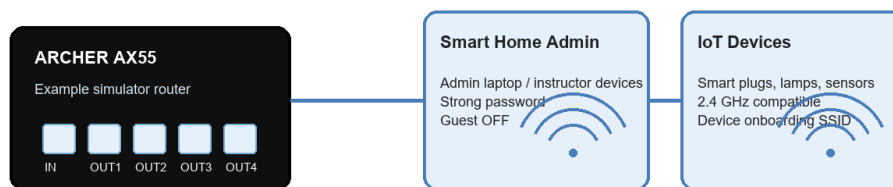
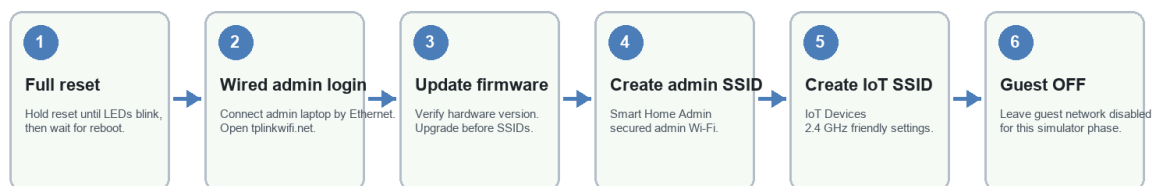

Configure firmware and Wi-Fi before enrolling smart-home devices. Record SSIDs, passwords, and firmware version.

Fig 1 — Recommended router setup sequence for the simulator.

PREP AND FULL RESET

1 **Connect for setup**
Connect the admin laptop to the router by Ethernet. Connect router power. If internet is needed for online firmware update, connect the router IN/WAN side to an internet source temporarily.

2 **Perform full factory reset**
Hold the router Reset button until the LEDs blink or the router restarts. Wait for the router to fully reboot before logging in.

3 **Open the web interface**
Open a browser to tplinkwifi.net. If that does not resolve, use the router IP shown by the admin laptop network settings, commonly 192.168.0.1 or 192.168.1.1.

4 **Create router admin login**
Set a strong administrator password. Store it in the instructor-approved password location, not on the student-facing wall.

ALT LOGIN: If the laptop cannot connect by wire first, connect to the router's default Wi-Fi, open a browser, and go to 192.168.0.1 or 192.168.1.1. If the TP-Link admin page opens, log in using the default password printed on the router label/back of the router. After the first login, immediately change the router admin password and record the new password location in this guide.

UPDATE FIRMWARE BEFORE WI-FI SETUP

1 **Find hardware version**
Check the router label for model and hardware version, such as Archer AX55 V1, V1.6, V4, or V4.6.

2 **Use official TP-Link support**
Use the TP-Link support/download page for the correct country/region and exact hardware version. Wrong firmware can damage the router.

3 **Run firmware upgrade**
In the web interface, go to the firmware update area, check online or upload the correct firmware file, and start the upgrade.

4

Wait without interruption

Do not unplug power, close the update page, or move cables during upgrade. Wait for reboot and confirm the router is responsive again.

5

Record firmware version

Write the installed firmware version/date in the configuration worksheet before creating SSIDs.

SSID PLAN

Simulator SSID plan

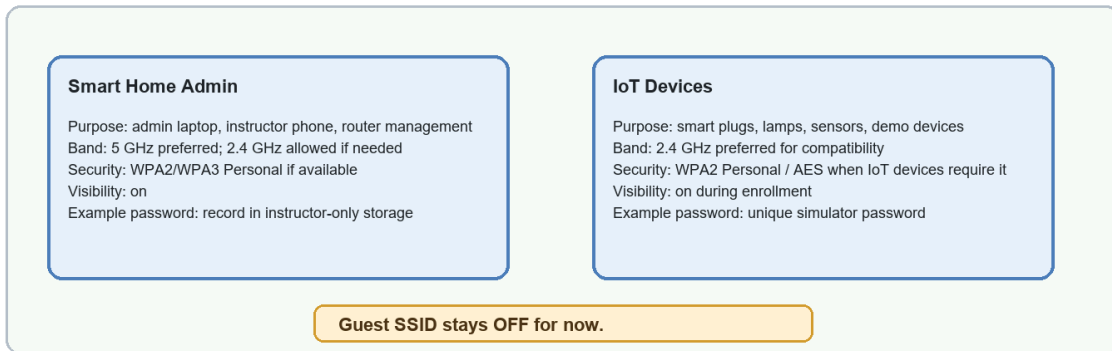

Fig 2 — Simulator wireless plan: Smart Home Admin and IoT Devices enabled; Guest Wi-Fi disabled.

NETWORK	SSID	PURPOSE	RECOMMENDED SETTINGS
Administration	IOT Smart Home - Admin	Admin laptop, instructor phone, router management	Strong password; WPA2/WPA3 if available; hide password from student-facing labels.
IOT Devices	IOT Smart Home - Devices	Alexa show, Tablet or phone for Alexa App, Smart plugs, lamps, sensors, and demo smart-home devices	2.4 GHz friendly; WPA2 Personal/AES when needed for compatibility.
Guest	OFF	Not used in this phase	Leave disabled until a later lab requires guest isolation.

CONFIGURE WIRELESS NETWORKS

1

Configure Smart Home Admin

In **Wireless settings**, set the admin SSID to Smart Home Admin. Use a strong password and security mode approved by the instructor. This network is for trusted admin devices.

2

Configure IoT Devices

Create or enable the IoT wireless network if the firmware provides one. Set SSID to IoT Devices. Prefer 2.4 GHz compatibility for smart plugs, lamps, and sensors.

3

Use fallback if no IoT menu exists

If this AX55 firmware does not show a separate IoT Network menu, use the normal 2.4 GHz wireless network for IoT Devices and reserve the other SSID/band for Smart Home Admin.

4

Turn Guest Network off

Open Guest Network settings and confirm guest SSID is disabled for both bands. Do not publish a guest SSID in this phase.

5

Save and reboot if prompted

Apply settings and let the router restart if required. Reconnect the admin laptop to Smart Home Admin only after the settings are saved.

CONFIRM DHCP SETTINGS

LATER LAB:

Access control lists, device isolation rules, firewall tuning, and router hardening are intentionally saved for a later security lab. For this phase, confirm basic DHCP and Wi-Fi operation only.

1

Open LAN / DHCP settings

In the router web interface, open the LAN or DHCP Server settings area. Menu names may vary by Archer AX55 firmware version.

2

Confirm DHCP server is enabled

The simulator router should hand out IP addresses automatically unless the instructor has provided a static-address lab plan.

3

Record LAN IP and subnet

Write down the router LAN IP, subnet mask, DHCP start address, DHCP end address, lease time, and DNS settings in the worksheet.

4**Check DHCP range size**

Make sure the range has enough addresses for the admin device, IoT devices, and test devices used in the class.

5**Verify client leases**

Connect devices. Confirm each receives an IP address, subnet mask, gateway, and DNS from the router.

TEST SIMULATOR WI-FI

TEST	DEVICE	EXPECTED RESULT	STATUS
Admin SSID visible	Admin laptop / phone	Smart Home Admin appears and accepts password.	[] Pass
IoT SSID visible	Smart device or phone	IoT Devices appears and accepts password.	[] Pass
Guest disabled	Admin laptop / phone	No guest SSID is visible.	[] Pass
DHCP admin lease	Admin laptop	Receives IP, gateway, and DNS from router DHCP.	[] Pass
DHCP IoT lease	IoT/test device	Receives IP, gateway, and DNS from router DHCP.	[] Pass
Patch-panel path	Laptop through keystone 7/8	Link light and network connectivity work through the patched path.	[] Pass
Router login	Admin laptop	Router admin page opens only from approved admin device/network.	[] Pass

CONFIGURATION WORKSHEET

FIELD	VALUE
Router model	
Hardware version	
Firmware version/date	
Admin password storage location	
Smart Home Admin password	
IoT Devices password	
Guest SSID status	
DHCP server status	
Router LAN IP	
Subnet mask	
DHCP range	
Lease time	
DNS settings	
ACL / hardening status	Deferred to later lab
Router management URL/IP	tplinkwifi.net / _____

NEXT PHASE — ADD SMART HOME DEVICES

<p>READY FOR DEVICE ENROLLMENT</p> <ul style="list-style-type: none"> Smart plugs Smart lamps / light sockets Sensors Controller app Device labels 	<p>DO NOT SKIP</p> <ul style="list-style-type: none"> Firmware updated DHCP confirmed Guest SSID off Passwords recorded safely SSID tests passed Patch-panel path verified ACL/hardening deferred
---	--

Smart Home Simulator — Build Guide 06

Add Echo Show 5, Alexa Account Setup, and Third-Party Device Apps

TYPE	PHASE	CONTROL LAYER	USE
Tabletop Simulator Panel	Alexa + Device Apps	Echo Show 5 / Alexa App	IoT / Smart Home Training

BEFORE:

Router Wi-Fi must already be configured from Guide 05. Use the Smart Home Admin SSID for admin phones/tablets and use the IoT Devices SSID for smart devices unless the instructor provides a different lab plan.

GOAL OF THIS PHASE

Add the Echo Show 5 to the simulator, complete the initial Alexa account setup, prepare the Alexa app, and get ready to install the separate third-party apps required by the lights, thermostat, doorbell camera, and other smart-home devices.

- Record Alexa account information in the worksheet before adding devices.
- Install physical brackets, bases, or plates for third-party devices before app setup.
- Each third-party device may need its own vendor app and account before it can sync to Alexa.
- Do not start automations or advanced routines until basic app and Alexa control tests pass.

SYSTEM FLOW

Alexa control layer: Echo Show 5 + third-party apps

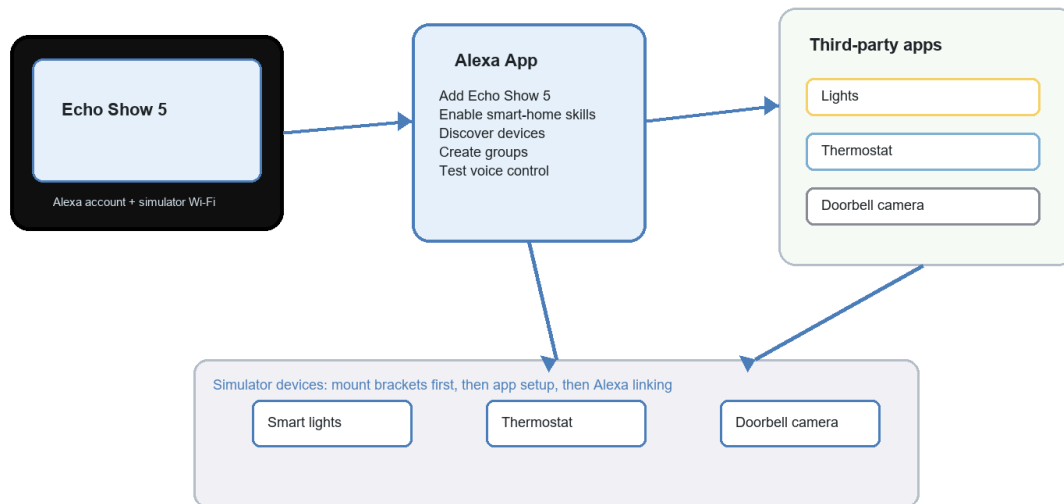

Each third-party app must be installed, configured, and linked to Alexa before the Echo Show can reliably control that device.

Fig 1 — Echo Show 5 and Alexa app become the control layer after third-party apps link their devices to Alexa.

SET UP ECHO SHOW 5

- 1** **Power on Echo Show 5**
Place it where students can see and hear the display. Connect power and wait for the setup screen.
- 2** **Connect to simulator Wi-Fi**
Use the Smart Home Admin SSID for the Echo Show 5 unless the instructor assigns it to a different network.
- 3** **Sign in with Alexa/Amazon account**
Use the simulator Alexa account. Do not use a personal student account for the shared demo wall.
- 4** **Confirm device appears in Alexa app**
Open the Alexa app on the admin phone/tablet and confirm the Echo Show 5 appears under Devices.

5

Name and place the Echo Show

Rename it to a clear simulator name, such as Demo Wall Echo Show 5, and assign it to the simulator room/group.

ALEXA ACCOUNT WORKSHEET

FIELD	VALUE / NOTES
Alexa/Amazon account email	
Password storage location	
Recovery email/phone	
MFA method / backup location	
Echo Show 5 device name	Demo Wall Echo Show 5
Alexa room/group name	
Admin phone/tablet used	
Instructor initials/date	

THIRD-PARTY DEVICE APP WORKFLOW

Repeat this setup pattern for each third-party device

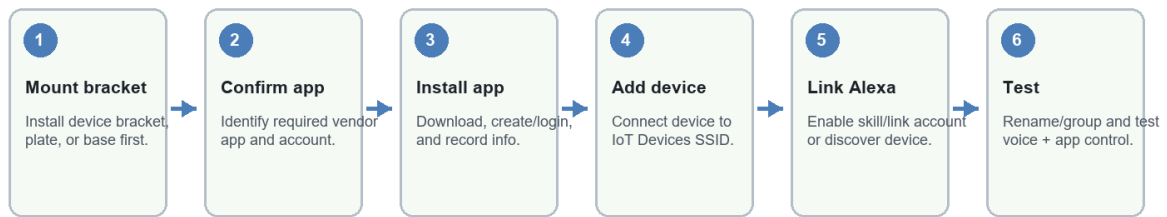

Examples: light app, thermostat app, doorbell camera app. Each app may have a different pairing mode, account login, and Alexa skill/linking step.

Do not move to the next phase until mounts are secure, apps are documented, devices appear in Alexa, and basic controls test pass.

Fig 2 — Repeat this workflow for lights, thermostat, doorbell camera, and any additional smart-home device.

1

Install mounting bracket first

Install the device bracket, base plate, wall plate, or camera mount before app pairing. Confirm it is secure and positioned correctly.

- 2** **Confirm required app**
Check the device label, QR code, quick-start card, or manufacturer instructions to identify the required app.
- 3** **Download and configure app**
Install the app on the admin phone/tablet. Create or log into the third-party account and record the account information in the worksheet.
- 4** **Add the device in its app**
Follow the vendor pairing steps. Connect Wi-Fi smart devices to the IoT Devices SSID unless the instructor specifies otherwise.
- 5** **Update device firmware if prompted**
Run firmware updates inside the vendor app before linking to Alexa when the app recommends it.
- 6** **Link to Alexa**
In the Alexa app, enable the matching skill or account link if required, sign into the third-party account, and discover devices.
- 7** **Rename, group, and test**
Use clear names like Demo Light 1 or Demo Doorbell. Add the device to the simulator room/group and test app control plus Alexa voice control.

THIRD-PARTY APP ACCOUNT WORKSHEET

DEVICE	APP NEEDED	ACCOUNT EMAIL	PASSWORD LOCATION	ALEXA LINKED?	NOTES
Lights				<input type="checkbox"/> Yes	
Thermostat				<input type="checkbox"/> Yes	
Doorbell camera				<input type="checkbox"/> Yes	
Other				<input type="checkbox"/> Yes	

DEVICE SETUP TRACKER

DEVICE	MOUNT INSTALLED	APP CONFIGURED	ALEXA DISCOVERED	TEST RESULT
--------	-----------------	----------------	------------------	-------------

Light 1	[]	[]	[]	
Light 2	[]	[]	[]	
Thermostat	[]	[]	[]	
Doorbell camera	[]	[]	[]	
Additional device	[]	[]	[]	

FINAL ALEXA READINESS CHECKLIST

CHECK	PASS CRITERIA	STATUS
Echo Show 5 online	Echo Show is powered, named, and visible in Alexa app.	[] Pass
Alexa account recorded	Account email and password storage location are documented.	[] Pass
Third-party apps listed	Required apps and account info locations are documented.	[] Pass
Mounts installed	Device brackets/bases/plates are secure before app pairing.	[] Pass
Devices discovered	Lights, thermostat, and doorbell camera appear in Alexa when available.	[] Pass
Voice test	Alexa can control or display each synced device as expected.	[] Pass
Ready for next phase	Basic control works before routines/scenes/security settings are added.	[] Pass

NEXT PHASE — BUILD THE HVAC SIMULATOR PROJECT BOX

<p>READY FOR GUIDE 07</p> <ul style="list-style-type: none"> HVAC project box Colored 24V LEDs 24V AC power supply Smart thermostat wiring Board mounting 	<p>DO NOT SKIP</p> <ul style="list-style-type: none"> Echo Show online Apps documented Third-party accounts linked Devices discovered Basic control tests passed
--	---

Smart Home Simulator — Build Guide 07

Build and Install the HVAC Simulator Module

TYPE	PHASE	MODULE	USE
Tabletop Simulator Panel	HVAC Simulator Install	Project box + smart thermostat	IoT / Smart Home Training

SAFETY: This guide is for a low-voltage HVAC simulator only. Do not connect the board directly to real HVAC equipment or line voltage. Use the instructor-approved transformer/power supply and verify power is off before wiring.

GOAL OF THIS PHASE

Build a low-voltage HVAC simulator project box with colored 24V LEDs, connect the 24V AC power supply, wire the smart thermostat terminals, mount the finished project box to the demo wall, and verify heat, cool, fan, stage 2, and common wiring.

- Cut and drill the project box before installing LEDs and wire strain relief.
- Mount brackets, standoffs, or backing plate before wiring the project box to the board.
- Label every terminal and wire on both ends.
- Use low-voltage power only and keep HVAC wiring separate from line-voltage wiring.
- Test the module before moving on to smart thermostat configuration.

MATERIALS, HARDWARE & TOOLS

QTY	ITEM	SPEC / NOTES
1	Smart thermostat and wall/base plate	Thermostat used to control the simulator calls.
1	Project box (3x6x2 min.)	Holds colored 24V LEDs and internal wiring.
1	24V AC low-voltage supply	Instructor-approved transformer/power supply sized for simulator load.
5	Colored 24V LED indicators	24Vac/power, cool, fan, heat, and stage 2 indicators.
5'	Thermostat, wire 5-7 conductor	5-conductor preferred for R, C, W, Y, G.
As needed	Small wire nuts	Use for low-voltage splices inside the project box; size to match conductor count and gauge.
As needed	Standoffs / brackets / backing plate	Secure the project box to the wall without stressing terminals.
As needed	Cable glands / grommets	Protect thermostat and power-supply wires where they enter the box.
As needed	Labels / wire markers	Label both ends of each conductor.
1	Multimeter	Verify low-voltage output and continuity before final test.
1	In-line fuse 1amp	1 amp Inline fuse for power supply wire.

MODULE LAYOUT

HVAC simulator project box wiring layout

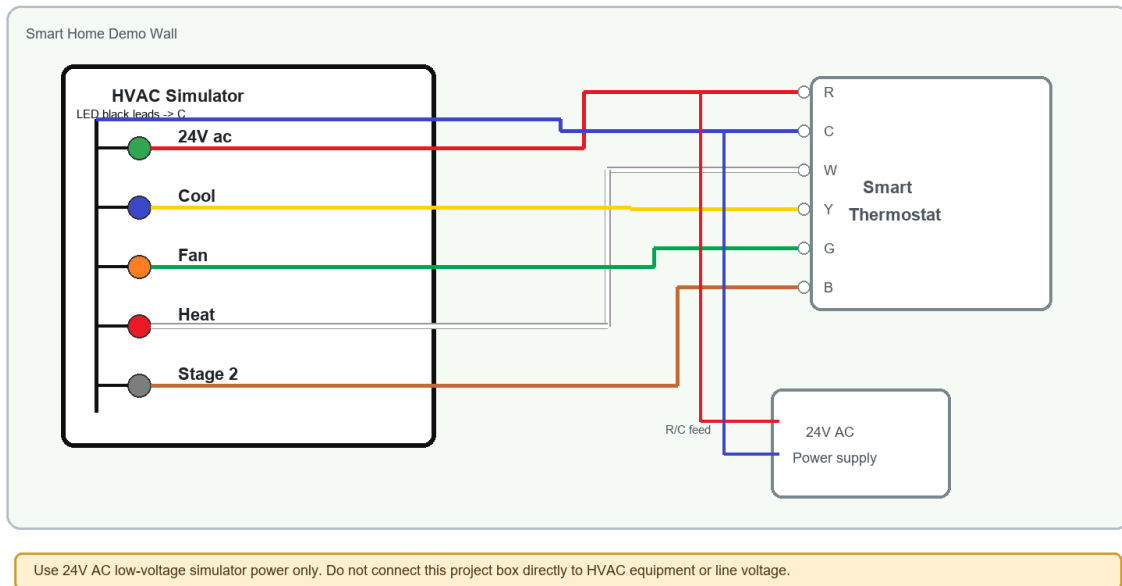

FIG 1:

Each LED red lead goes to its matching call wire. Each LED black lead returns to the blue C/common wire. Mount the completed project box to the demo board after wiring is tested.

TERMINAL REFERENCE

HVAC simulator terminal reference

R	24V power	Feeds thermostat/simulator control power and 24V LED bus.
C	Common	Completes the 24V AC circuit for thermostat and LEDs.
W	Heat call	Turns on the red HEAT LED.
Y	Cool call	Turns on the blue COOL LED.
G	Fan call	Turns on the orange FAN LED.
B	Stage 2 / aux call	Turns on the gray STAGE 2 LED if used by the thermostat/lab.

Wire colors may vary by kit. Match labels and terminal function first; document the color actually used.

Fig 2 — HVAC simulator terminal functions. Match labels and document the wire colors actually used.

BUILD THE HVAC SIMULATOR PROJECT BOX

- 1** Lay out the project box face
Mark LED positions for 24Vac, Cool, Fan, Heat, and Stage 2. Keep labels readable from the front of the demo wall.
- 2** Drill LED and wire-entry holes
Drill clean holes for the colored LEDs and cable glands/grommets. Deburr plastic edges so wires are not cut by the box.
- 3** Install colored 24V LEDs
Install LEDs in the project box: green for 24Vac/power, blue for Cool, orange for Fan, red for Heat, and gray for Stage 2.
- 4** Label each LED and wire
Label the outside of the box and label internal conductors. Include R, C, W, Y, G, and B/Stage 2 labels.
- 5** Wire LED common and call leads
Use C/common as the LED return/common as required by the LED type. Route W to Heat, Y to Cool, G to Fan, and B to Stage 2. Use small wire nuts for approved low-voltage splices inside the project box.
- 6** Connect 24V AC power supply
Wire the low-voltage supply to the simulator R and C feed points. Protect the power-supply wire where it enters the project box.
- 7** Inspect wire nuts and bench test
Confirm each small wire nut is tight and no bare copper is exposed below the connector. With instructor approval, power the 24V supply and verify the power LED turns on. Momentarily test each call LED before closing the box.

INSTALL THE PROJECT BOX TO THE DEMO WALL

- 1** Choose mounting location
Place the project box where students can read LED labels and where wire routing will not cross line-voltage wiring.
- 2** Install brackets or standoffs
Mount the backing plate, brackets, or standoffs first. Confirm the project box will sit flat and can be opened for service.
- 3** Attach project box
Fasten the project box to the mount. Do not over-tighten screws into plastic. Keep the lid removable if students need to inspect wiring.
- 4** Route thermostat wire
Route the thermostat wire neatly from smart thermostat location to the project box. Leave service loops at both ends.
- 5** Secure wire path
Use cable clips or Velcro ties. Avoid sharp bends and keep low-voltage wiring separated from power wiring.
- 6** Install covers and labels
Add any terminal covers, wire labels, and front-facing labels before testing.

WIRE SMART THERMOSTAT TO PROJECT BOX

TERMINAL	FUNCTION	SKETCH COLOR	CONNECTS TO	CHECK
R	24V power	Red	Thermostat R / project box R feed	Green 24Vac LED/power feed active.
C	Common	Blue	Thermostat C / project box C common	Smart thermostat has common.
W	Heat call	White/gray	Thermostat W / red Heat LED	Heat LED responds.
Y	Cool call	Yellow	Thermostat Y / blue Cool LED	Cool LED responds.

G	Fan call	Green	Thermostat G / orange Fan LED	Fan LED responds.
B or W2	Stage 2 / aux call	Brown/orange	Thermostat B / gray Stage 2 LED	Stage 2 LED responds if used.

TEST AND DOCUMENT

TEST	ACTION	EXPECTED RESULT	STATUS
Power	Apply 24V AC simulator power	Green 24Vac LED powers without call LEDs stuck on.	<input type="checkbox"/> Pass
Heat	Activate W call	HEAT indicator/load turns on.	<input type="checkbox"/> Pass
Cool	Activate Y call	COOL indicator/load turns on.	<input type="checkbox"/> Pass
Fan	Activate G call	FAN indicator/load turns on.	<input type="checkbox"/> Pass
Stage 2	Activate B/Stage 2 call if used	STAGE 2 indicator turns on.	<input type="checkbox"/> Pass
Wire nuts	Gently tug each low-voltage splice	Small wire nuts stay tight and no bare copper is exposed.	<input type="checkbox"/> Pass
Common	Verify smart thermostat C wire	Thermostat remains powered through R/C.	<input type="checkbox"/> Pass
Mount	Gently move wall/project box	Project box, lid, power supply, and wires stay secure.	<input type="checkbox"/> Pass

HVAC BUILD WORKSHEET

FIELD	VALUE / NOTES
Smart thermostat model	
Project box size/type	
Low-voltage supply rating	
24Vac LED color used	
Cool LED color used	
Fan LED color used	
Heat LED color used	
Stage 2 LED color used	
R wire color used	
C wire color used	

W wire color used	
Y wire color used	
G wire color used	
B or W2 wire color used	
Mounting location	
Instructor initials/date	

NEXT PHASE — CONFIGURE SMART THERMOSTAT AND SMART DEVICES

<p>READY FOR CONFIGURATION</p> <ul style="list-style-type: none"> Thermostat app Alexa linking Heating/cooling/fan test Room assignment Demo commands 	<p>DO NOT SKIP</p> <ul style="list-style-type: none"> 24V low-voltage only Wires labeled both ends Small wire nuts secure Project box mounted securely Colored LEDs tested Worksheet completed
--	--

Smart Home Simulator — Build Guide 08

Configure Smart Thermostat and Smart Devices

TYPE	PHASE	CONTROL	USE
Tabletop Simulator Panel	Smart Device Configuration	Apps + Alexa + Echo Show 5	IoT / Smart Home Training

BEFORE:	Complete Guide 07 first. The HVAC project box, colored LEDs, 24V AC power supply, smart thermostat wiring, router Wi-Fi, Alexa account, and third-party app accounts should be ready before this configuration phase.
----------------	---

GOAL OF THIS PHASE

Configure the smart thermostat and smart-home devices so they work in their vendor apps, appear in Alexa, respond through the Echo Show 5, and trigger the correct physical simulator response.

- Configure the smart thermostat in its own app before linking it to Alexa.
- Confirm HVAC terminals and system type match the project box: R, C, W, Y, G, and B/Stage 2 if used.
- Configure lights, doorbell camera, and additional devices in their own third-party apps first.
- Link each vendor app/account to Alexa, discover devices, rename them clearly, and test app plus voice control.

CONFIGURATION FLOW

Configure smart thermostat and smart devices

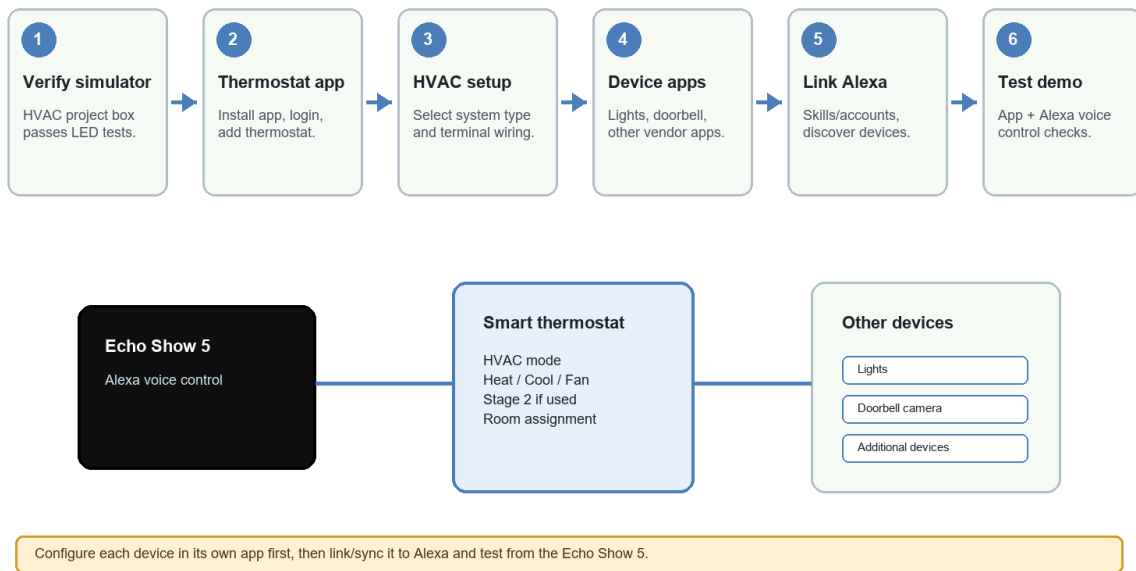

Fig 1 — Configure each device in its own app first, then link/sync to Alexa and test from the Echo Show 5.

CONFIGURE THE SMART THERMOSTAT

1 Install the thermostat app
Use the app required by the thermostat brand. Sign in with the simulator account and record the account/password storage location.

2 Add thermostat to app
Follow the app pairing steps. Connect the thermostat to the IoT Devices SSID unless the instructor assigns it to Smart Home Admin.

3 Select HVAC system type
Choose the simulator system type that matches the project box. Use heat/cool/fan and Stage 2/B only if wired and supported by the thermostat.

4

Confirm terminal detection

Verify the app or thermostat screen sees R, C, W, Y, G, and B/Stage 2 as expected. Correct wiring before continuing.

5

Name and assign room

Use a clear name such as Demo Thermostat and assign it to the simulator room/group.

6

Run heat/cool/fan tests

Call for heat, cool, fan, and Stage 2 if used. Confirm the matching LED lights on the HVAC project box.

CONFIGURE OTHER SMART DEVICES

1

Confirm device app

Identify the required app for each light, thermostat accessory, doorbell camera, or other device.

2

Install bracket or mount first

Install any mounting bracket, base, plate, or camera mount before pairing the device in the app.

3

Add device in vendor app

Create/login to the vendor account, connect the device to the IoT Devices SSID, and update firmware if prompted.

4

Rename in vendor app

Use clear simulator names: Demo Light 1, Demo Light 2, Demo Doorbell, Demo Thermostat, etc.

5

Confirm app control

Before linking to Alexa, verify the vendor app can control or view the device reliably.

LINK DEVICES TO ALEXA

1

Open Alexa app

Use the simulator Alexa account from Guide 06.

2**Enable skill or link account**

For each third-party app, enable the matching Alexa skill or account link if required.

3**Discover devices**

Run device discovery in Alexa. Confirm the thermostat, lights, doorbell camera, and any additional devices appear.

4**Rename and group**

Use consistent names and assign devices to the simulator room/group so Echo Show commands are predictable.

5**Test on Echo Show 5**

Use voice and display controls to test each device. Fix app linking or names before creating routines.

DEVICE CONFIGURATION WORKSHEET

DEVICE	APP	ACCOUNT	WIFI	ALEXA NAME	TEST RESULT
Smart thermostat			IoT Devices / Admin	Demo Thermostat	
Light 1			IoT Devices	Demo Light 1	
Light 2			IoT Devices	Demo Light 2	
Doorbell camera			IoT Devices	Demo Doorbell	
Additional device					

FINAL TEST PATH

Final smart-home simulator test path

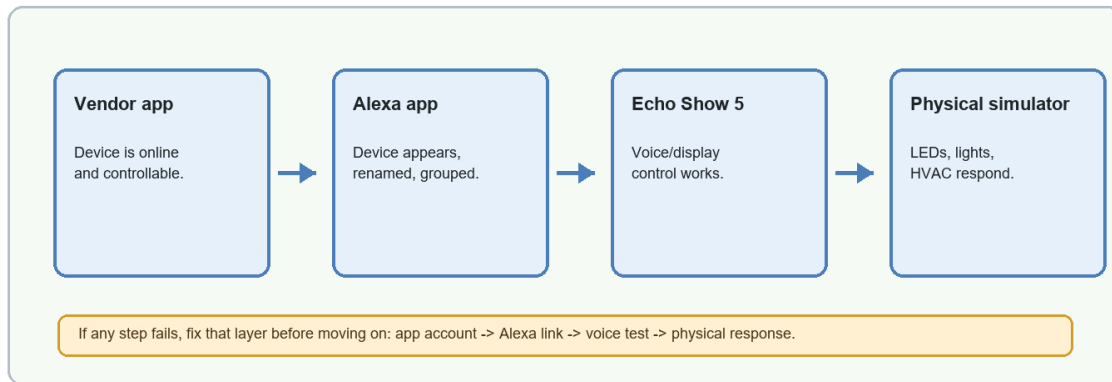

Fig 2 — Test every device through its vendor app, Alexa app, Echo Show 5, and physical simulator response.

FINAL CONFIGURATION CHECKLIST

CHECK	PASS CRITERIA	STATUS
Thermostat app	Thermostat is online and configured with correct HVAC terminals/system type.	[] Pass
HVAC response	Heat, cool, fan, and Stage 2 if used light the correct LEDs.	[] Pass
Lights	Lights respond in vendor app and Alexa.	[] Pass
Doorbell camera	Camera appears in vendor app and Alexa/Echo Show if supported.	[] Pass
Alexa discovery	All intended devices appear with clear names.	[] Pass
Echo Show voice test	Echo Show controls thermostat/lights and displays camera where supported.	[] Pass
Documentation	Accounts, app names, Wi-Fi, device names, and test results are recorded.	[] Pass

NEXT PHASE — BUILD ROUTINES AND DEMO SCENARIOS

READY FOR AUTOMATION Alexa routines Scenes Voice commands Demo scripts Student scenarios	DO NOT SKIP Thermostat tested LED calls verified Apps linked to Alexa Device names clean Worksheet complete
---	--

Smart Home Simulator — Build Guide 09

Build Routines and Demo Scenarios

TYPE	PHASE	CONTROL	USE
Tabletop Simulator Panel	Routines + Demo Scenarios	Alexa App / Echo Show 5	IoT / Smart Home Training

BEFORE:

Complete Guide 08 first. The thermostat, lights, doorbell camera, Alexa app, and Echo Show 5 should already be linked, named, grouped, and tested before building routines.

GOAL OF THIS PHASE

Create simple Alexa routines and demo scenarios that students can trigger, observe, test, and reset. Keep routines predictable so the simulator can be used repeatedly in class.

- Each demo routine needs a clear trigger, device actions, expected physical response, and reset step.
- Use clear voice phrases that match the scenario, such as Alexa, start good morning demo.
- Avoid complex security or access-control logic in this phase; focus on observable smart-home behavior.
- Document every routine so another instructor can rebuild or troubleshoot it.

ROUTINE DESIGN FLOW

Build routines and demo scenarios

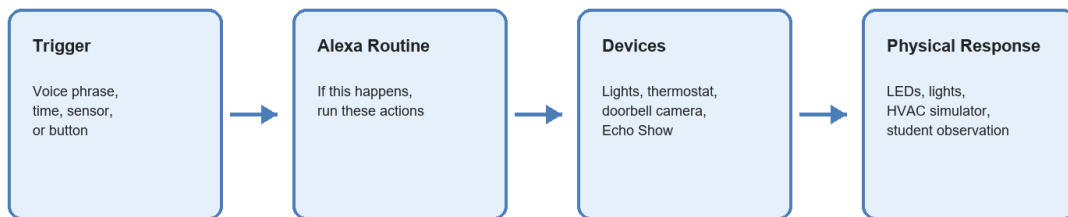

Recommended first demo routines

Good morning demo

Turn lights on, set thermostat, show camera.

Away mode demo

Turn lights off, lower HVAC, show doorbell status.

Doorbell event demo

Show camera feed and announce visitor.

Routines should be simple, repeatable, and easy for students to reset between demonstrations.

Fig 1 — A good demo routine has a trigger, actions, visible device response, and reset plan.

BUILD THE FIRST ROUTINE

1 Open Alexa app routines
Open the Alexa app using the simulator account. Go to More > Routines or the current Routines menu.

2 Create routine name
Use a clear name such as Demo 01 - Good Morning. Avoid vague names like Test 1.

3 Choose trigger
Select voice trigger, schedule, smart device trigger, or button trigger. Voice is easiest for the first classroom demo.

4 Add actions
Add device actions for lights, thermostat mode/temperature, Echo Show announcement, or camera display if supported.

5 Save and test
Run the routine from the Alexa app first, then test by voice on the Echo Show 5.

6 Create reset routine
Build a matching reset routine that returns lights, thermostat, and camera display to the start state.

RECOMMENDED DEMO SCENARIOS

SCENARIO	TRIGGER	ACTIONS	RESET
Good Morning	Alexa, start good morning demo	Turn on selected lights; set thermostat to comfort setpoint; announce demo start.	Turn lights off or neutral; return thermostat to default.
Away Mode	Alexa, start away mode demo	Turn off lights; set thermostat to away setpoint; announce away mode.	Return lights and thermostat to normal demo state.
Doorbell Event	Alexa, show doorbell demo	Show doorbell camera on Echo Show if supported; announce visitor.	Stop camera display; return Echo Show to home screen.
HVAC Heat Call	Alexa, start heat demo	Set thermostat to call heat; verify red Heat LED.	Return thermostat setpoint so heat call stops.

HVAC Cool Call	Alexa, start cool demo	Set thermostat to call cooling; verify blue Cool LED.	Return thermostat setpoint so cool call stops.
----------------	------------------------	---	--

ROUTINE BUILD WORKSHEET

ROUTINE NAME	TRIGGER	DEVICES USED	EXPECTED RESPONSE	RESET ROUTINE

TEST CYCLE

Demo scenario test cycle

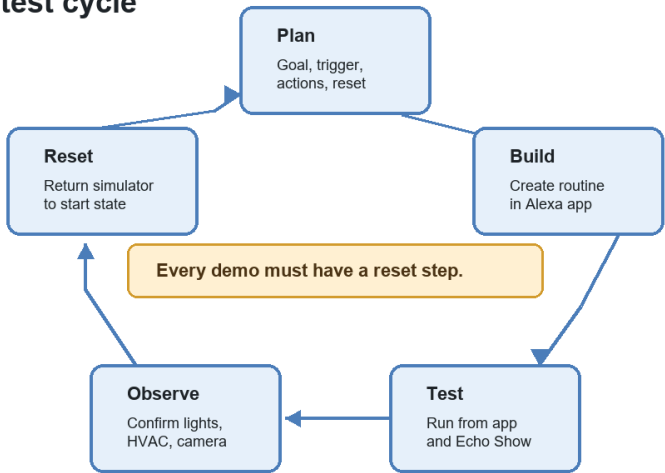

Fig 2 — Test every demo with the same cycle: plan, build, test, observe, reset.

STUDENT DEMO SCRIPT

- 1

Introduce the scenario
 Explain what real smart-home behavior the routine is modeling.

- 2

Show the trigger
 Have the student read or press the trigger. Keep phrasing visible on the worksheet or label.

3**Observe physical response**

Students watch lights, HVAC LEDs, Echo Show, or doorbell camera response.

4**Ask what happened**

Have students identify which device/app/Alexa layer caused each response.

5**Run reset**

Return the simulator to its starting state before the next student or group.

FINAL ROUTINE CHECKLIST

CHECK	PASS CRITERIA	STATUS
Routine names	Names are clear and numbered for classroom use.	<input type="checkbox"/> Pass
Triggers	Triggers are easy to say or perform.	<input type="checkbox"/> Pass
Device actions	Lights, thermostat, doorbell, and Echo Show actions work as expected.	<input type="checkbox"/> Pass
Physical response	Students can observe a visible simulator response.	<input type="checkbox"/> Pass
Reset routine	Each demo has a reset or manual reset instruction.	<input type="checkbox"/> Pass
Worksheet complete	Triggers, actions, expected results, and reset steps are documented.	<input type="checkbox"/> Pass

NEXT PHASE — USER GUIDE AND STUDENT LABS

READY FOR USER GUIDE

Student workflow
 Demo scripts
 Troubleshooting
 Reset procedure
 Instructor notes

DO NOT SKIP

Routines tested
 Resets tested
 Expected responses documented
 Device names clean
 Worksheets complete

Smart Home Demo Wall – Build Guide 10

Harden the Router and Network

Phase	Audience	Example Router	Goal
Guide 10	Builder / instructor	TP-Link Archer AX55 or similar	Secure the simulator network

Purpose	This guide hardens the router and simulator network after the smart-home devices are working. The goal is to reduce unnecessary access while keeping the board useful for demos and later student labs.
----------------	---

BEFORE YOU HARDEN THE NETWORK

Start from a known working simulator. The lights, Echo Show, thermostat, HVAC simulator, doorbell/camera, router, and patch panel should already be installed and tested.

Done	Hardening Item	Evidence / Notes
[]	Router is powered on and reachable	Record current router login method before changing settings.
[]	Firmware has been checked	Update firmware before changing security controls.
[]	Smart Home Admin SSID works	Instructor phone/laptop can connect and manage the system.
[]	IoT Devices SSID works	Smart devices are online and visible in their apps.
[]	Guest SSID is off	Leave guest off unless a later lab specifically enables it.
[]	Demo routines still run	Run one known routine before hardening so there is a baseline.

HARDENED NETWORK MODEL

Use two working zones for this simulator: an admin zone for the instructor/demo controller and an IoT zone for smart-home devices. The guest network stays off for this lab.

Hardened simulator network model

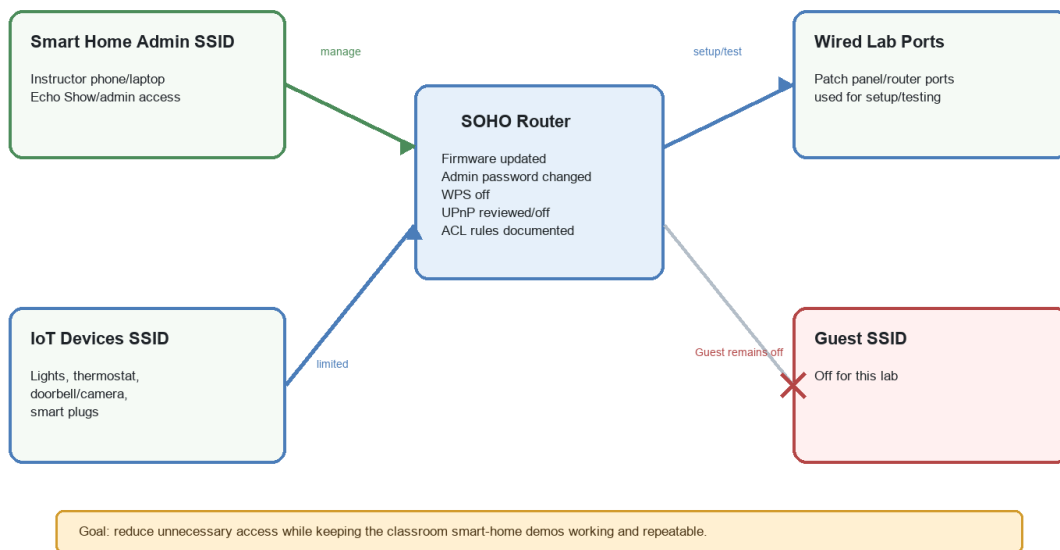

HARDENING WORKFLOW

Router hardening workflow

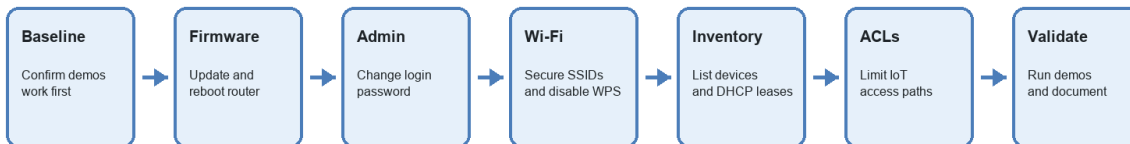

If a hardening change breaks a demo, document it, roll back only that setting, and test again.

1 **Confirm baseline operation**
Run one light demo, one HVAC simulator demo, and one Alexa routine before changing router security settings.

2 **Update firmware first**
Log in to the router, check firmware, install updates, and allow the router to reboot fully.

3 **Change the router administrator password**
Use a strong password. Record the storage location for the password, not the password itself, in student-facing documents.

4 **Secure Wi-Fi settings**
Use WPA2/WPA3 where available, strong SSID passwords, and clear SSID names for Smart Home Admin and IoT Devices.

5 **Disable WPS**
Turn off WPS so devices cannot be added by push-button or PIN pairing during the demo.

6**Review UPnP**

Disable UPnP unless a specific smart-home device requires it for the lab. If enabled, document why.

7**Create the device inventory**

Record each device, MAC address if available, assigned IP address, app used, and network zone.

8**Apply ACL or isolation rules**

Limit IoT Devices from reaching admin devices where the router supports it. Keep required internet/cloud access for demos.

9**Validate and document**

Run every demo again and write down which settings were changed.

RECOMMENDED SECURITY SETTINGS

Setting	Recommended Lab Value	Reason
Router firmware	Current version installed	Fixes known bugs and security issues before the lab starts.
Router admin password	Changed from default	Prevents default-label password use during demos.
Remote management	Off unless required	Reduces external management exposure.
WPS	Off	Prevents easy unauthorized Wi-Fi enrollment.
Guest SSID	Off for now	Keeps the simulator focused on Admin and IoT networks.
Wi-Fi encryption	WPA2/WPA3 personal where available	Protects wireless traffic with modern authentication.
SSID passwords	Strong unique values	Avoids reuse with personal or campus networks.
UPnP	Off unless documented	Reduces automatic port-opening behavior.

DHCP	On, with known range	Keeps setup simple while allowing inventory tracking.
DHCP reservations	Use for key devices if available	Makes troubleshooting easier for thermostat, Echo Show, camera, and admin laptop.

DHCP AND DEVICE INVENTORY

Confirm DHCP is enabled on the router and record the active DHCP range. For a classroom simulator, DHCP reservations are useful for devices that are checked often, such as the Echo Show, thermostat, camera, and instructor laptop.

Device	Network	MAC / Serial	IP Address	Reserved?
Instructor laptop/phone	Smart Home Admin			
Echo Show 5	Smart Home Admin or IoT Devices			
Smart thermostat	IoT Devices			
Doorbell/camera	IoT Devices			
Smart light 1	IoT Devices			
Smart light 2	IoT Devices			
Router LAN	Management		192.168.0.1	N/A

ACCESS CONTROL LIST PLAN

Teaching Note	MAC filtering is useful for inventory discussions, but it should not be taught as strong security by itself. The stronger controls are good passwords, firmware updates, WPS off, network separation, and tested ACL/isolation rules.
----------------------	---

Traffic Path	Allow / Block	Reason
Admin device to router management page	Allow	Instructor or builder must manage the simulator.
Admin device to smart-device apps/cloud	Allow	Needed to configure and test devices.
IoT devices to internet/cloud services	Allow	Most smart devices require vendor cloud access.
IoT devices to admin laptop/phone	Block if supported	Reduces device-to-admin exposure.
Guest clients to simulator devices	Block / Guest off	Guest network is not used in this lab.

Unknown wireless clients	Block by password control	Do not share SSID passwords outside the lab team.
--------------------------	---------------------------	---

VALIDATION TESTS

Done	Hardening Item	Evidence / Notes
[]	Admin device can log in to router	Use the new router admin password.
[]	Smart Home Admin SSID connects	Confirm internet and router management access.
[]	IoT Devices SSID connects smart devices	Confirm all expected devices show online.
[]	Alexa routine runs	Run Good Morning or Away Mode.
[]	Smart light responds	Test app and voice control.
[]	Thermostat can call HVAC simulator	Confirm correct LED response.
[]	Doorbell/camera loads	Confirm app or Echo Show display response.
[]	Guest SSID remains off	Confirm it is not visible or not enabled.
[]	ACL/isolation does not break demos	If broken, document the rule and adjust only that setting.

TROUBLESHOOTING AFTER HARDENING

Issue	Likely Cause	Fix
Device disappeared from app	SSID password changed or device joined wrong network	Reconnect device to IoT Devices SSID and retest.
Alexa routine partly fails	One device offline or blocked by isolation	Test each device manually, then review ACL rules.
Cannot reach router admin page	Admin device on IoT SSID or wrong gateway	Move admin device to Smart Home Admin SSID and browse to router IP.
Camera feed fails	Cloud access blocked or weak Wi-Fi	Allow required internet access and move camera/router closer for testing.
Thermostat app offline	Thermostat lost Wi-Fi after password change	Reconnect thermostat to IoT Devices SSID.

Hardening change broke several demos	Rule too broad	Disable the last rule, test, then create a narrower rule.
--------------------------------------	----------------	---

FINAL HARDENING CHECKLIST

Done	Hardening Item	Evidence / Notes
<input type="checkbox"/>	Firmware updated and router rebooted	Record firmware version/date.
<input type="checkbox"/>	Router admin password changed	Record secure storage location.
<input type="checkbox"/>	Smart Home Admin and IoT Devices SSIDs secured	Record SSID names and storage location for passwords.
<input type="checkbox"/>	WPS disabled	Confirm setting after router reboot.
<input type="checkbox"/>	Guest SSID off	Leave disabled for this phase.
<input type="checkbox"/>	UPnP reviewed	Off unless a lab need is documented.
<input type="checkbox"/>	DHCP range recorded	Reservations added where useful.
<input type="checkbox"/>	Device inventory completed	Include device name, app, network, and IP.
<input type="checkbox"/>	ACL/isolation rules tested	Demos still work after hardening.
<input type="checkbox"/>	Router configuration backed up	Export/save config if router supports it.

NEXT PHASE

After the router and network are hardened, the simulator is ready for repeatable instructor demos, user-guide field setup, and student troubleshooting labs. Later labs can intentionally break one setting at a time so students can diagnose Wi-Fi, DHCP, ACL, app, and device-cloud problems.

NOTES:

Prepared by Sonny Bever

Copyright © 2026 Sonny Bever. All rights reserved.

For classroom, booth, and smart-home simulator training use.